

TYPE

# BIL 1300 kV

BIL	1300 kV					
	TAPERED			UNIFORM		
Style	TAPERED			UNIFORM		
Catalog Number	1300 ST	1300 HT	1300 ET	1300 SU	1300 HU	1300 EU
ANSI Technical Reference	TR324	TR367	TR369	TR324		TR368
Non ANSI Description	1300-1000	1300-1450	1300-2050	1300-1000	1300-1450	1300-2050
<b>Dimensions</b>						
Leakage Distance (in)	231	231	231	231	231	231
Height (in)	106	106	106	106	106	106
Max Shed Diameter (in)	8	8.3	9.2	8	8.6	9.3
Top BCD (in)	5	5	5	5	7	7
Diameter Dt (in)	6.3	6.2	6.3	6.3	8.7	8.7
Bottom BCD (in)	5	7	7	5	7.1	7
Diameter Db (in)	6.3	8.7	8.7	6.3	8.7	8.7
<b>Mechanical Values</b>						
Cantilever Strength, Upright, Pounds	1000	1450	2050	1000	20.12	2050
Tensile Strength, Pounds	25000	20000	40000	25000	20000	40000
Torsion Strength, Inch-Pounds	90000	40000	90000	90000	40000	120000
Compression Strength, Pounds	75000	60000	150000	75000	60000	120000
<b>Electrical Values</b>						
Impulse Flashover, Positive, kV	1410	1410	1410	1410	1410	1410
Low Frequency Withstand, 10 Sec. Wet, kV	525	525	525	525	525	525
Impulse Withstand, kV	1300	1300	1300	1300	1300	1300
<b>Radio Influence Voltage Data</b>						
Test Voltage, Rms to Ground, kV	220	220	220	220	220	220
Maximum RIV, Microvolts at 1000kHz	1000	1000	1000	1000	1000	1000
<b>Weight</b>						
Approximate Net Weight, Pounds	324	320	457	326	406	512

S = Standard Strength    U = Uniform, Upright and Underhung    P = Pollution/High Leakage    BCD = Bolt Circle Diameter  
 H = High Strength    T = Tapered, Upright Only    Y = Higher Cantilever Option    Dt = Diameter Top Fitting  
 E = Extra High Strength    V = Inverted    Z = Higher Cantilever Option    Db = Diameter Bottom Fitting

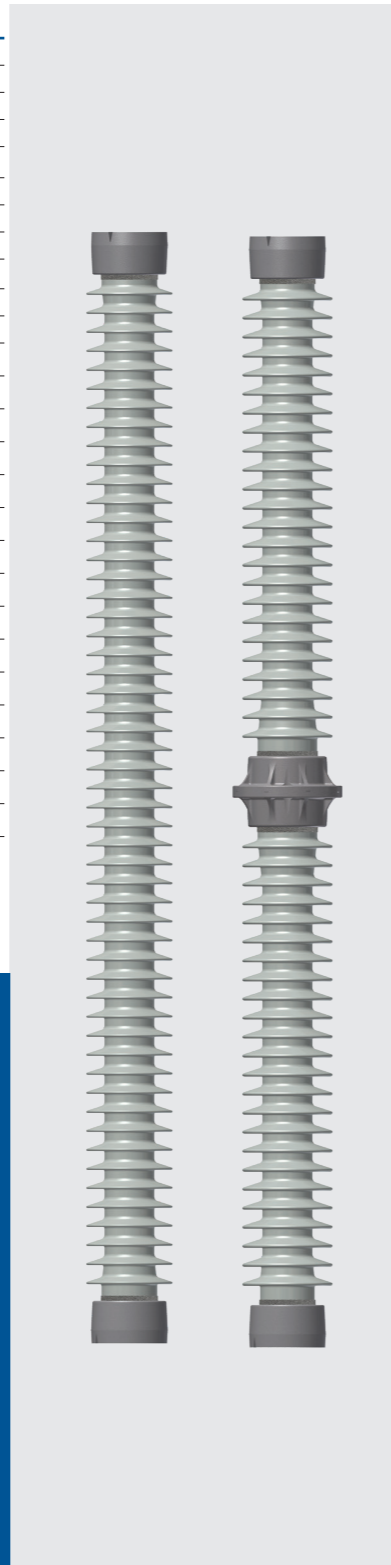
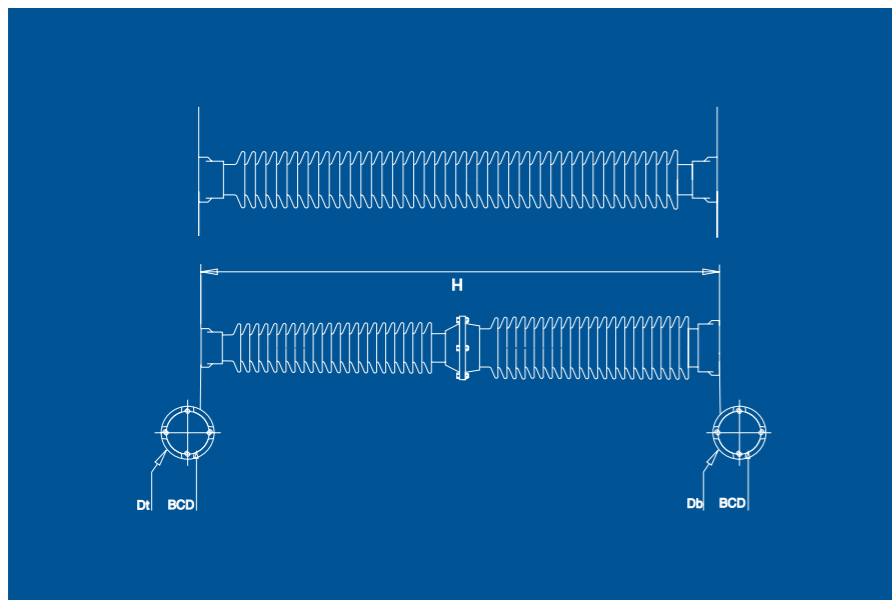

TYPE

# BIL 1300 kV

BIL	1300 kV				
	TAPERED		HIGH LEAKAGE		
Style	TAPERED		HIGH LEAKAGE		
Catalog Number	1300 YT	1300 ZT	1300 STP	1300 HTP	1300 ETP
ANSI Technical Reference					
Non ANSI Description	1300-3000	1300-4000	1300-1000	1300-1450	1300-2050
<b>Dimensions</b>					
Leakage Distance (in)	231	231	326	322	315
Height (in)	106	106	106	106	106
Max Shed Diameter (in)	10	10.5	9.1	9.7	10.5
Top BCD (in)	5	5	5	5	5
Diameter Dt (in)	6.3	6.3	6.3	6.2	6.3
Bottom BCD (in)	12	12	5	7	7
Diameter Db (in)	13.2	13.4	6.3	8.7	8.7
<b>Mechanical Values</b>					
Cantilever Strength, Upright, Pounds	3000	4000	1000	1450	2050
Tensile Strength, Pounds	40000	40000	25000	20000	20000
Torsion Strength, Inch-Pounds	133000	133000	90000	40000	40000
Compression Strength, Pounds	150000	150000	75000	60000	60000
<b>Electrical Values</b>					
Impulse Flashover, Positive, kV	1410	1410	1410	1410	1410
Low Frequency Withstand, 10 Sec. Wet, kV	525	525	525	525	525
Impulse Withstand, kV	1300	1300	1300	1300	1300
<b>Radio Influence Voltage Data</b>					
Test Voltage, Rms to Ground, kV	220	220	220	220	220
Maximum RIV, Microvolts at 1000kHz	1000	1000	1000	1000	1000
<b>Weight</b>					
Approximate Net Weight, Pounds	507	544	357	381	481

S = Standard Strength    U = Uniform, Upright and Underhung    P = Pollution/High Leakage    BCD = Bolt Circle Diameter  
 H = High Strength    T = Tapered, Upright Only    Y = Higher Cantilever Option    Dt = Diameter Top Fitting  
 E = Extra High Strength    V = Inverted    Z = Higher Cantilever Option    Db = Diameter Bottom Fitting

